



Stirred Reactors and Pressure Vessels

Bulletin 4500 | Volume 12

Designing
and Building
Quality
Pressure
Apparatus
for Over
100 Years

Start

Chapter Five

This pdf is just one chapter from our Catalog 4500. Please refer to all six chapters to make the proper equipment choice for your needs.

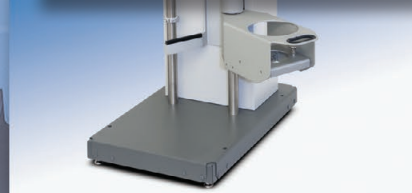

12



Chapter 5

Optional Fittings



Inside this chapter you will find:

[HEATER OPTIONS](#)

[STIRRER MOTORS AND DRIVES](#)

[STIRRER OPTIONS](#)

[GAS ENTRAINMENT](#)

[CATALYST BASKETS](#)

[CONDENSERS](#)

[SAFETY RUPTURE DISCS](#)

[PRESSURE RELIEF VALVES](#)

[PRESSURE GAGES](#)

[GAS MEASUREMENT SYSTEMS](#)

[HIGH PRESSURE BURETTES](#)

[LIQUID CHARGING SYSTEMS](#)

[METERING PUMPS](#)

[LIQUID PIPETTES](#)

[SOLIDS CHARGING SYSTEMS](#)

[COOLING COILS](#)

[CYLINDER LINERS](#)

[SAMPLE COLLECTION VESSEL](#)

[BOTTOM DRAIN VALVES](#)

[VALVES AND FITTINGS](#)

[SAFETY CHECK VALVES](#)

[THERMOCOUPLES](#)

[PRESSURE HOSE](#)

[EXPLOSION PROOF APPARATUS](#)

[WINDOWS](#)

[INSULATED ELECTRICAL GLANDS](#)

[SPARE PARTS KITS](#)

[TEMPERATURE LIMITS](#)

[EXTERNAL VALVES AND FITTINGS](#)

Parr has designed standard electrical heaters for all of the reactors in our product line. Different types of heaters are used for individual reactors to best meet the operational needs, heating load, and expected operating temperatures. The standard heater type and power rating for each reactor model is listed in the reactor specification tables. The standard designs will typically be one of the following:

Clamp-On Band Heaters

These are normally used for very small reactors where maximum watt densities and heat transfer are required due to the limited surface area available on the vessel.

Rigid Heating Mantles.

These are quartz fabric mantles housed in aluminum shells. They are used for moderate sized reactors in designs where the heater can be moved on or off the vessel. They are light weight and easy to handle, but they are not used to support the weight of the vessel and they are generally limited to operating temperatures of 350 °C or less.

Calrod-Type Sheathed Element Heaters.

These are rugged heaters with Calrod-type elements held within a metal shell. They are used for medium to large reactors for operating temperatures to 350 °C. In some cases the heater shell itself forms a part of the reactor support. An advantage of Calrod heaters is that the heating elements are easily replaceable.

Ceramic Heaters.

These are special purpose heaters with an electric element embedded in a shaped ceramic body which is held within an insulated metal housing. They are used for

reactors designed for temperatures to 600 °C and for large multi-zone heaters.

Optional and Custom Heaters.

Parr offers a variety of heater designs which can be substituted for the standard heater normally furnished with each reactor. Most of these can also be used with Parr non-stirred pressure vessels as well. The principal features and recommended applications for these heaters are described below.

Flexible Heating Mantles.

These can be furnished for many different applications. These are similar to the rigid type described above except they are not held in an aluminum housing. They have a flexible fabric outer case for electrical and thermal insulation. This type of mantle is particularly useful for heating vessels with irregular shapes, such as those with windows in the cylinder wall, since they are flexible and can be split and laced onto a vessel around any external protrusion. As with rigid mantles, they will produce temperatures up to 350 °C, but they are limited to watt densities of 10 watts per square inch. This type of heater can be made to cover any of the vessels offered by Parr, and they are sometimes preferred when only moderate temperatures are required. Since they are constructed of cloth, an electrical ground wire cannot be provided.

Aluminum Block Heaters.

These are available as an option for most reactors and pressure vessels. For vessels of two gallons or less the heaters are machined from solid blocks of aluminum and heater wells are machined into the walls of the block. Optional

cooling channels are also included.

Aluminum block heaters have three distinct features which make them ideal for many applications:

1. Since the heating elements are sealed within these housings, explosive vapors cannot reach them and the heater can be considered explosion proof, provided it is equipped with optional explosion proof wiring and a safety cut-out to ensure that the heater will not exceed a specified temperature limit allowed for the explosive atmosphere.
2. With heat spread uniformly throughout the aluminum block, uniform heating is applied to all surfaces of the vessel, comparable to the rapid response obtained with a steam or hot oil jacket, but without requiring costly steam generators, oil baths, circulating pumps and other accessory equipment.
3. Since there is a cooling coil in the aluminum block, this style heater can also provide external cooling for controlling an exothermic reaction without the internal clutter and cleaning problems associated with internal cooling coils. Eliminating an internal coil also permits the use of spiral, paddle or other stirrers which cannot be used when an internal coil is installed.

Circulation Jackets.

A jacket can be welded to the outer wall of most Parr pressure vessels to provide a means for heating or cooling the vessel with a hot or cold liquid or steam. This type of heating is ideal for users who want to duplicate plant operating conditions, using a jacketed reactor comparable



to jacketed equipment used in their plant. Since there are no electrical components in a jacket, and since the maximum temperature can be controlled by controlling the temperature of the heating medium, a jacketed vessel will be accepted as explosion proof and suitable for use in hazardous atmospheres.

Rapid and uniform heating can be attained with a jacketed vessel since the heating medium is in direct contact with the vessel. By controlling the temperature of the heating medium, temperature overshoots can be avoided when working with sensitive materials. Standard jackets are designed for operating pressures up to 100 psig (7 bar) within the jacket. Higher pressure jackets can be provided if required.



Cylinder, 2000 mL, with Welded Circulating Jacket.



Model 4666 2-Gallon Non-Stirred Reactor with Welded Jacket, Hinged Split Rings, Pneumatic Lift, and Bottom Drain Valve.



Aluminum Block Heater with Cooling Channel and Heat Shield for 1000 mL Vessel.

Stirrer Motors and Drives

Torque vs. Stirring Speed

The standard, open-type, variable speed motor installed on each Parr reactor will produce stirring speeds from zero to between 600 and 800 rpm with a torque adequate to drive the installed impellers in average viscosity mixtures. Higher horsepower motors and special stirrers can be provided for higher viscosities. Alternate drive pulleys are available to produce higher stirring speeds, but several basic rules must be considered when changing any of these components.

The highest torque from any motor is obtained at lower stirring speeds. Increasing the stirring speed reduces the torque in inverse proportion to the speed. For operations involving high viscosity mixtures, the motor size, the type of impeller and the stir-

ring speed must be matched to provide an effective mixing system.

As a general rule, the magnetic coupling installed on each Parr reactor will have a torque rating considerably higher than the torque obtainable from the motors offered for use with that apparatus. The goal is to make the motor the weak link so that the magnetic stirrer will be protected. Reference torque rating for applicable magnetic drive.

Explosion Proof Motors

Explosion proof motors designed for Class I, Groups C and D and Class II, Groups F and G with variable speed control can be furnished for most Parr reactors.

Air Motors

Air-driven motors can be installed on most reactors. The horsepower rating, torque, and

available speed are all dependent upon the pressure and available volume of the driving air source. Maximum torques are delivered at relatively slow speeds and maximum horsepower is delivered at high speed.

Geared, Direct Drive Motors

A geared, direct drive motor can be installed on most fixed head floor stand reactors. This is an attractive arrangement for handling heavy stirring loads.

Any 1/4 hp or larger, variable-speed standard or explosion-proof motor can be used. Gear box drives are available with ratios of 3:1, 5:1 and 10:1. The 1700 rpm maximum speed will be reduced in an amount determined by the reduction ratio of the gear box, and the associated torque values from the table will be increased in the same ratio.

Stirrer Drive Motors

Motor Designation	HP Rating	Explosion Proof	Variable Speed	Standard Pulley		Optional Pulley	
				Max Speed, RPM*	Max Torque, in-lb	Max Speed, RPM*	Max Torque, in-lb
-VS.12	1/8	No	Yes	600	12	1700	4
-XP.25	1/4	Yes	Yes	600	27	1700	9
-AM.25**	1/4	Yes	Yes	1000**	30**	—	—
-VS.25	1/4	No	Yes	600	27	1700	9
-VS.50	1/2	No	Yes	600	54	1700	18
-XP.50	1/2	Yes	Yes	600	54	1700	18
-AM.50**	1/2	Yes	Yes	1000**	66**	—	—
-VS.75	3/4	No	Yes	600	81	1700	27
-XP.75	3/4	Yes	Yes	600	81	1700	27

Values represented are nominal.

VS = variable speed, XP = explosion proof, AM = air motor, 1 in-lb = 0.11 Nm, 1 hp = 0.75 Kw

*Maximum speed values based on "no load"

**HP, RPM, and torque values for air motors are based on a 40psi supply capable of 34cfm for the AM.50 and 10cfm for the AM.25.



Parr Geared Drive Motor mounted on a Series 4553 Stirred Reactor System.

Gear Box Torques

Motor HP Rating	3:1 Gear Box		5:1 Gear Box		10:1 Gear Box	
	Max Speed, RPM	Max Torque, in-lb	Max Speed, RPM	Max Torque, in-lb	Max Speed, RPM	Max Torque, in-lb
1/4	600	27	360	45	180	90
1/2	600	54	360	90	180	180
3/4	600	81	360	135	Not Recommended	

Magnetic Drive

Description	Maximum Torque, in-lb
General Purpose	16
Footless General Purpose	16
Heavy Duty	60
Footless Heavy Duty	60
Extra Heavy Duty	120
Footless Extra Heavy Duty	120

Stirrer Options



Turbine Type Impeller



Anchor Stirrer



Spiral Stirrer



Paddle Type Anchor



Gas Entrainment Impeller



Anchor Stirrer with Wiper Blades

Turbine Type Impellers

Parr reactors are usually equipped with turbine type impellers which produce an excellent mixing action over the range of stirring speeds at which these reactors typically operate. These impellers are made in four-blade and six-blade styles, with the smaller four-blade impellers used only on Micro and Mini Reactors. These impellers, for reactors with 300 mL volume or greater, may be positioned anywhere on the stirring shaft, with one impeller usually located near the bottom of the vessel to keep solids up in suspension and a second impeller positioned near the base of the vortex to pull reactant gases down into the liquid phase. These impellers generally provide excellent mixing for systems with effective viscosities up to approximately 25,000 centipoise (cP) with a 16 in-lb magnetic drive or up to 50,000 cP with 60 in-lb magnetic drive.

Anchor Stirrers

Anchor stirrers are available in several configurations for use with moderate to high viscosity materials. This type of stirrer usually works best in vessels with an inside depth to diameter ratio of 1.5 to 1 or less. They are intended to operate at relatively slow speeds and generally require a heavy duty drive system capable of generating and delivering sufficient torque to the agitator. Footless magnetic drives work well with anchor or spiral stirrers.

Three basic types are offered:

1. A U-shaped, flat bar anchor.
2. A flat blade, paddle type anchor.
3. A two-arm or three-arm, self centering anchor with PTFE wiper blades.

All of these designs may not be appropriate or available for each reactor size. Please contact the Parr Technical Service Department for assistance in selecting an anchor stirrer suitable for the intended operating volume and viscosities.

Spiral Stirrers

Spiral stirrers can be installed in any 1 liter, 2 liter or 1 gallon reactor to produce a positive downward thrust or upward thrust action when working with viscous polymers or other high viscosity mixtures. They work best in floor stand reactors with adjustable speed and heavy duty drive systems. Either left-hand (downward thrust) or right hand (upward thrust) spirals are available. The downward thrust spiral is generally preferred for heavy suspensions.

Note:

Additional internal fittings may be required to adapt some stirrer styles to existing reactors in the field.

Gas Entrainment Impellers



Parr offers a series of gas entrainment impellers for users who want to obtain maximum gas dispersion into a liquid system. This is obtained with a unique impeller attached to a hollow stirring shaft through which gases are continuously recirculated from the head space above the liquid through the impeller into the liquid phase. As with all impellers, the speed of the stirrer creates a vacuum at the tip of the impeller. Gas enters openings near the top of the shaft and is pulled through dispersion ports located at the tips of the impellers. In the Parr system with dispersion ports located at the very tips of the impellers, the higher the stirring speed — the higher the vacuum — and the higher the driving force for this very effective gas dispersion system.

These impellers are offered as a complete package which includes the impeller, the hollow shaft with coupling, and any required foot bearings and brackets for the intended reaction. The baffles are a separate option which must be ordered individually.

The gas entrainment stirrers may be ordered as an optional stirrer when purchasing a new reactor system or easily installed in an existing system in the field. With the wide variety of reactor head styles and magnetic stirrers furnished on Parr reactors it is best to contact us with the numbers stamped on the head of your vessel so that we will be able to furnish the correct gas entrainment assembly for a particular reactor system.



Gas Entrainment Impeller

Since these gas entrainment impellers operate best in the 1000-1200 rpm range, users will want to ensure that their stirrer drive system is set up to deliver these operating speeds; alternate pulleys and belts are available to convert existing reactor systems.

Baffles

Because it is the relative speed of the tip of the impeller to the liquid phase that governs the mass transfer, baffles, which impede the rotation of the liquid with the impeller, can greatly enhance the operation of these gas entrainment impellers. While some natural baffling is provided by the internal thermowell, dip tube and cooling coils, the removable baffles are recommended for use with these gas entrainment impellers. These baffles may also be beneficial with the more traditional turbine type impellers for certain applications.



Gas Entrainment Impeller with Hollow Shaft



Removeable Baffle Set

Catalyst Baskets



Catalyst Basket Static Design

Catalyst baskets can be provided for holding a supported catalyst so that it will not be destroyed or changed by the stirring action of the impeller. These can be installed in reactors with volumes ranging from 300 to 2000 mL. Two interchangeable styles are available. Special heads, internal cooling coils, thermowells and dip tubes are required to provide clear space in the vessel for these baskets.

The Static Design

In the static design the mesh basket holding the catalyst remains stationary while impellers on the stirring shaft and baffles outside of the basket direct the flow of reactants over the surface of the contained catalyst. A unique gas entrainment impeller provides a uniform flow of both gas and liquid over the fixed catalyst bed held within the annular basket. The Parr design for these baskets includes a rigid bottom support which permits high speed stirring without excessive vibration. Cooling coils, internal temperature measurements, and liquid and gas sampling operations can be continued as usual without interference from the installed catalyst basket.

The Dynamic Design

In the dynamic design the catalyst is held in an annular shaped, mesh basket which is attached to the stirrer drive in place of the stirring shaft. The rotating basket then serves as an impeller for stirring the reactants. Fixed baffles and coaxial impellers ensure good circulation over the surface of the contained catalyst. The dynamic baskets are available for reactors with volumes of 1000, 1800, and 2000 mL. Dynamic baskets must be installed in reactors equipped with at least 1/4 hp motors to ensure that sufficient stirrer torque and speeds are available for proper operation. Dynamic baskets are interchangeable with static baskets in 1 liter and larger vessels.



Catalyst Basket Dynamic Design

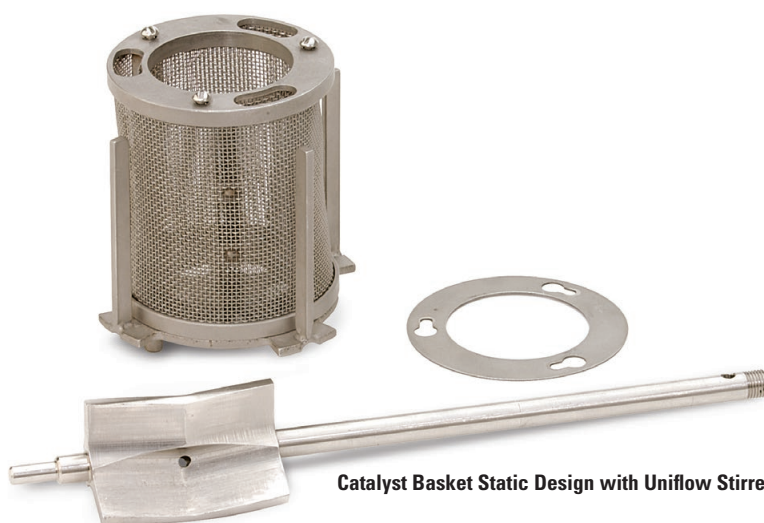

Catalyst Basket Static Design with Uniflow Stirrer

Condensers



Parr offers two styles of condensers for attachment to the head of a stirred reactor or pressure vessel. These can be made in various sizes to match the size of the reactor.

Straight Reflux Condenser

The reflux condenser consists of a length of tubing connected directly to the head of a vessel and equipped with a water cooling jacket. Condensed vapors are returned directly to the vessel and any non-condensable gases can be released through a needle valve at the top of the condenser. A spiral wound inner packing in the condenser ensures maximum effectiveness in a rather short length.

Reflux/Take-Off Condensers

The reflux/take-off condenser consists of a water jacketed tube, the same as described above, assembled with a receiving vessel attached to the lower end of the condenser. Any vapor, such as water from a polymerization reaction, can be condensed and collected in the receiver, from which it can be withdrawn through a bottom valve. Any non-condensable gases can be released through a needle

valve at the top of the condenser. If condensate collection is not required, the receiver can be removed and the condenser can be mounted directly above the reactor for direct reflux into the vessel.

Modifications

Many users opt to install a ball valve at the head of the reactor below the condenser to use as a shut-off to the condenser. Alternate collection vessel volumes are available upon request.

The installation of a condenser on any of the Parr reactors requires a larger port in the head of the vessel, the size of which will vary with the volume of the reactor system. Due to the limited space on the 4560 mini reactors we would change either the gage opening or one of the cooling coil ports to 1/4" NPT for use with a condenser. This modification would then either combine the gage and condenser functions or eliminate the internal cooling loop to accommodate the condenser. Reactors with volumes of 1 liter and greater would be modified with a 3/8" NPT opening or larger depending on the reactor volume. The standard head fittings would be rearranged to accommodate this port.



Straight Reflux Condenser

Reflux Take-Off Condenser

Condensers

Reactor	Style	Note	Inner Tube Diameter, in.	Standard Receiver, mL	Part No.
4560 / 4590	Reflux/Take-off	Mod. Gage Opening 1/4" NPT	1/4	150	A2011HC
4560 / 4590	Reflux	Mod. Gage Opening 1/4" NPT	1/4		A2012HC
4560	Reflux/Take-off	Mod. Cool Coil Opening 1/4" NPT	1/4	150	A2013HC
4560	Reflux	Mod. Cool Coil Opening 1/4" NPT	1/4		A2014HC
4520 / 4530 / 4550	Reflux/Take-off	3/8" NPT	3/8	300	A2001HC
4520 / 4530 / 4550	Reflux	3/8" NPT	3/8		A2002HC
4530	Reflux/Take-Off	3/8" NPT	3/8	300	A2003HC
4530	Reflux	3/8" NPT	3/8		A2004HC
4540 / 4570 / 4580	Reflux/Take-off	3/8" NPT	3/8	300	A2016HC
4540 / 4570 / 4580	Reflux	3/8" NPT	3/8		A2017HC
4555 / 4556	Reflux/Take-off	1/2" NPT	3/4	1000	A2018HC
4555 / 4556	Reflux	1/2" NPT	3/4		A2019HC

Safety Rupture Discs



A888HC2 Rupture Disc Assembly

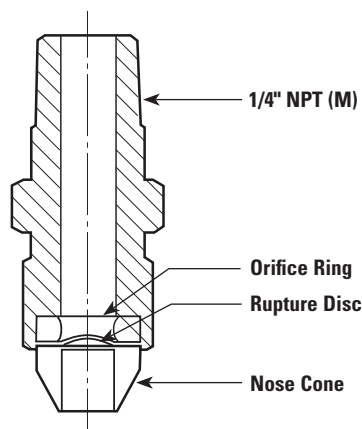

Parr Pressure Vessels are protected by custom built rupture discs furnished by Fike® Corporation, a specialist in this exotic art. Examination of these discs will indicate that each of these discs is domed. This dome was produced at the factory by taking the individual disc to 70% of its burst pressure.

The ASME as well as other pressure vessel codes dictate that pressure vessels must be equipped with a rupture disc designed to burst no higher than the design pressure of the vessel. For pressure loads that do not cycle rapidly such as our vessels, Fike suggests limiting the actual operating pressure to no more than 90% of its burst pressure. This combination will limit operating pressures to no more than 90% of the design pressure of the vessel.

We have selected alloy 600 as the standard material for these rupture discs. It provides excellent corrosion resistance while retaining over 90% of its room temperature rating at temperatures up to 450 °C. For added corrosion resistance we can furnish these discs with gold facing or replace them with discs made of Alloy C276. Discs can be produced to match any operating pressure and temperature above the stated minimums.

Parr reactors and pressure vessels from 25 mL to 2000 mL use the 526HC alloy 600 disc or 581HC alloy 600 with gold facing. The 1 gallon and larger use the 708HC series discs. The 4580 reactor systems use the 1415HC series discs. For a complete listing of part numbers, burst ranges and materials see Manual 231M.

In general, the 1000 psi disc in the 526HC/581HC series discs and the 800 psi in the 708HC are the lowest available ranges in the alloy 600 material. Alternate disc materials are available but they do not offer the same corrosion resistant properties and temperature capabilities.

For applications where users prefer a lower range pressure gage, we would add a spring loaded relief valve set to protect the gage and a 1000 psi rupture disc as the fail safe protection.

Users are invited to contact the Parr Technical Support Staff with requirements for special rupture discs.

Rupture Discs for 1/4" Orifice

Burst Rating, psig	Inconel Disc	Gold-Faced Inconel Disc
1000	526HCPD	581HCPD
2000	526HCPF	581HCPF
3000	526HCPG	581HCPG
4000	526HCP40CT	581HCP40CT
5000	526HCPH	581HCPH
8000	526HCPJ	581HCPJ
10000	526HCP100CT	

Rupture Discs for 1/2" Orifice

Burst Rating, psig	Inconel Disc
1000	708HCP10CT
1500	708HCP16CT
2000	708HCP20CT
3000	708HCP30CT
3000	1415HCP30CT
4500	1415HCP45CT

Pressure Relief Valves

Spring-loaded relief valves should be viewed as supplements and not substitutes for a safety rupture disc which is the primary means protecting the vessel and the operator in case of accidental over-pressure. Spring loaded relief valves can be added to a reactor or vessel to:

- **Relieve** pressures near the maximum operating pressure.
- **Reseal** once excess pressure has been relieved.
- **Protect** low pressure components at pressures below available rupture disc ranges.

The relief valves listed below can be installed on any Parr vessel. These relief valves are stainless steel and have FKM O-rings. Other valves and O-ring materials are available on special order.

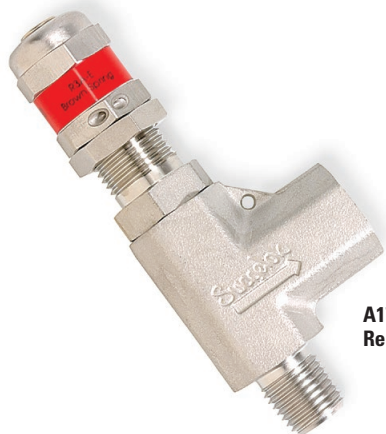

A175VB Relief Valve

Pressure Relief Valves

Part No.	Relief Pressure Range, psi	Discharge Connection
A140VB2PA	50-150	1/4" NPT (M)
A140VB2PB	150-350	1/4" NPT (M)
A140VB2PC	350-600	1/4" NPT (M)
A175VB	750-1500	1/4" NPT (F)
A175VB2	1500-2250	1/4" NPT (F)
A175VB3	2250-3000	1/4" NPT (F)
A175VB4	3000-4000	1/4" NPT (F)
A175VB5	4000-5000	1/4" NPT (F)

Note: When ordering any of the above relief valves, the user may specify a desired set pressure.

Gages



593HCPF Gage 3-1/2" Dia.



56HCPF Gage 4-1/2" Dia.



2633HCP10AD 3-1/2" Back Mount Gage

Gages for Parr pressure vessels can be furnished with either 3-1/2" or 4-1/2" dials in any of the ranges shown in the table below. All have stainless steel Bourdon tubes and 1/4" NPT male connections.

Alloy 400 gages are available on special order. Accuracy is .5 percent of full scale for the 4-1/2" size and 1 percent for the 3-1/2" gages. All are calibrated in both

pounds per square inch (psi) and bars. Gages in Pascal units are available on special order. Compound gages which show vacuum to 30 inches of Mercury and positive pressures to 300 psi (20 bar) are also available.

When ordering a special gage, specify the gage diameter, the desired range and scale units.

The gage on a pressure vessel should be 150 percent of the maximum operating pressure. This allows the gage to operate in the most accurate pressure range and prevents the gage from being stressed repeatedly to its full range, which will effect the calibration.

Gages

Pressure, psi	Range, bar	4-1/2" Dia. Gage No.	3-1/2" Dia. Gage No.	3-1/2" Dia. Back Mount Gage No.
0-100	0-14	56HCPA	593HCP1AD	2633HCP1AD
0-200	0-28	56HCPB	593HCP2AD	2633HCP2AD
0-600	0-40	56HCPD	593HCP6AD	2633HCP6AD
0-1000	0-70	56HCPD	593HCPD	2633HCP10AD
0-2000	0-137	56HCPF	593HCPF	2633HCP20AD
0-3000	0-210	56HCG	593HCPG	2633HCP30AD
0-4000	0-280	NA	593HCP40AD	—
0-5000	0-350	56HCPH	593HCP50AD	—
0-7500	0-517	56HCP75AD	NA	—
0-10000	0-700	56HCPK	NA	—
30" Hg Vac/300 psi		56HCP3YB	593HCP3YB	2633HCP3YB

Parr offers a variety of accessories for its line of pressure reaction vessels to enable the investigator to accurately determine the amount of gas consumed in a reaction conducted at elevated pressures and temperatures. There are essentially two methods used to measure the amount of gas delivered to a reaction vessel. These are:

- 1. The measurement** of the pressure drop in an auxiliary supply vessel of known volume.
- 2. The measurement and integration** of the flow rates using an electronic mass flow meter.

Each of these methods has its advantages and limitations as discussed below.

Intermediate Supply Tanks

Certainly the simplest method to measure the amount of gas consumed in a reaction is to feed the gas from a vessel of known volume and to measure the pressure drop in this vessel during the course of the reaction. The consideration in this method is to select a supply vessel with a volume matched to the amount of gas that will be consumed in the reaction. It needs to be large enough to contain enough gas to complete the reaction and small enough that the pressure drop will be significant and measurable. This basic technique can be applied in a number of ways:

- 1. The supply tank can be connected directly** to the reaction vessel. This is the simplest and least expensive. The principal limitation of this approach is that the reaction pressure will fall as gas is consumed and the reaction will not be conducted at a constant pressure.

- 2. The supply tank can be fitted with a constant pressure regulator.** The regulator must be selected to match the planned operating pressure. This regulator will deliver gas to the reaction vessel at constant pressure overcoming the limitation described in (1) above.

- 3. Initial and final pressures in the supply tank** can be measured with analog gages, or continuous pressure readings can be made and recorded using pressure transducers. While the transducers add cost, they also add increased resolution and the opportunity to follow the rate of the pressure drop and hence the rate of reaction.

- 4. Enhanced precision can be achieved** by measuring the temperature in the supply tank and applying corrections as appropriate.

Parr has put together a series of high pressure burettes in complete packages for direct connection to our reactors. The basic ones are listed on the following page.

These burettes can also be equipped with digital pressure transducers, internal thermocouples and data acquisition and reduction support. Please contact our customer support group for information on these possibilities.

Mass Flow Meters

Contact Parr Technical Service for help with mass flow meters or controllers. Because these meters must be individually specified and calibrated to the specified gas as well as the desired flow rate and operating pressure, no attempt has been made here to identify the possible selections and specifications.

The main consideration in selecting mass flow meters is to specify a pressure and a measurement range appropriate to the reaction. Some additional considerations are:

- **Mass flow meters** tend to have an accuracy of 1% of the full-scale flow rate. Since the meter must be sized to record the maximum expected flow rate, the accuracy is poor when the reaction is nearly completed and the flow rate is lower. Some systems overcome this by placing two meters in parallel and shifting over to the lower flow rate meter once the initial surge is over.
- **Meters are calibrated** for a specific gas. If the user will work with only one gas, e.g. hydrogen, this is not a significant restriction.
- **Electronic flow meters** are relatively fragile and must be protected with filters to ensure reliable service.

Mass Flow Controllers

Mass Flow Controllers add an automated control valve to the mass flow meter to provide gas flows that are proportional to an electronic set point. Although normally used to provide a constant flow rate to reactors operated in a continuous-flow mode, a unique application in batch reactions is to allow the set point to be dictated by the error signal from the reactor pressure transducer. As gas is consumed, the pressure drop signal can be configured to increase inlet flow. This signal can be sent to multiple controllers, enabling the make-up gas to be a mixture with an operator-specified ratio. This technique is often used in the study of co-polymers and ter-polymers.



High Pressure Gas Burettes

Parr offers a series of high pressure burettes intended to introduce gas (commonly hydrogen) to a reactor at a constant pressure. The burettes consist of a high pressure reservoir equipped with an inlet valve, a pressure gage and a relief valve. A constant pressure regulator with a check valve, a connecting hose and a support stand are included with each pipette.

The amount of gas consumed in a reaction can be determined by knowing the volume of the high pressure reservoir and observing the pressure drop in the reservoir during a reaction.

Parr high pressure burettes can be furnished in various sizes as shown in the adjoining table, each with a regulator to deliver gas to the reactor over the designated pressure range. The moles of gas shown in the table represent the amount of hydrogen that will be held in the burette at the maximum pressure. The deliverable volume will be a function of the difference in pressure between the pipette and the reactor. The size of the burette selected should be large enough to provide sufficient gas to complete the reaction while still maintaining sufficient pressure in the burette to force gas into the reactor.

Reservoirs with larger volumes are available as are regulators with different delivery ranges. Modifications can be made to these basic systems to add an internal thermocouple to the reservoir and/or a pressure transducer for digital readout and/or recording.

High Pressure Gas Burettes

Burette			Delivery Pressure Range		
Volume, mL	Maximum Pressure, psi	Total H ₂ Volume, Moles	0-1800 psi	0-1200 psi	0-700 psi
150	1800	0.8	A2280HC	A2280HC2	A2280HC3
300	1800	1.5	A2281HC	A2281HC2	A2281HC3
500	1800	2.6	A2282HC	A2282HC2	A2282HC3
1000	1800	5.1	A2283HC	A2283HC2	A2283HC3
2250	1800	11.5	A2284HC	A2284HC2	A2284HC3
500	5000	7.1	A2285HC	A2285HC2	A2285HC3



A2283HC High Pressure Gas Burette

Liquid Charging Systems

Liquid Metering Pumps

Liquid metering pumps are commonly used to introduce liquids into a reactor or vessel at elevated pressures on a continuous basis. A wide variety of pumps are available to meet various pressure, flow, and control requirements. The pumps listed here cover some of the more common pressure and flow requirements associated with Parr reactors and pressure vessels. The pumps

described under these catalog numbers include an inlet filter, a reverse-flow check valve and the outlet tubing to the

reactor. Special pumps can be furnished to meet requirements outside the range of these pumps.

Liquid Metering Pumps

Part No.	Flow Rate, mL/min	Pressure, Max. psi	Wetted Material	Remote Control 0-10 VDC
A2286HC	0.01-10	2500	PEEK	No
A2287HC	0.01-10	5000	Stainless	No
A2288HC	0.04-40	1500	Stainless	No
A2289HC	0.01-10	5000	Stainless	Yes
A2290HC	0.04-40	1500	Stainless	Yes
A2291HC	1.0-80	5000	Stainless	No

Solids Charging Systems

Liquid Charging Pipettes

To introduce liquids into reactors or vessels at elevated pressures, the most economical way is to use a pressure pipette as a secondary vessel. These are often used for liquid addition to a batch process. Liquid is forced into the reactor from the pipette by applying gas pressure to the pipette greater than the pressure within the vessel. If the passages in the connecting line are large enough, slurries or catalyst suspensions can also be charged into the reactor in this manner.

The pipettes listed below offer a choice of volumes and are rated for pressures to 1800 psi. They include a nitrogen filling connection for attachment to a nitrogen tank. More elaborate pipette systems can be assembled to special order to include additional fittings, such as a pressure gage for the pipette, a pressure relief valve or a large opening ball valve. Special pipettes can also be furnished for higher pressures to 5000 psi.

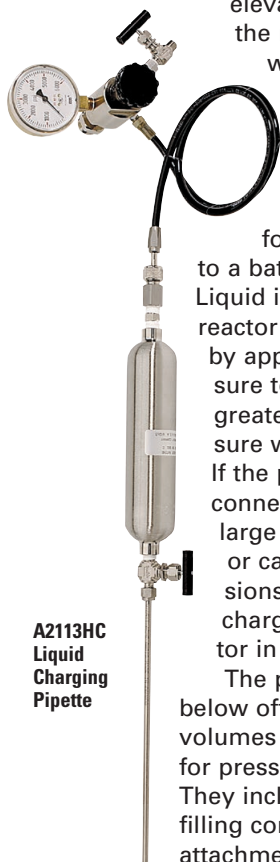

A2113HC
Liquid
Charging
Pipette

Liquid Charging Pipettes

Part No.	Pipette Volume, mL	Pressure Rating, psi
A2113HC3	50	1800
A2113HC4	150	1800
A2113HC	300	1800
A2113HC2	1000	1800

One of the modifications most frequently requested is a port or other means to feed liquids, solids, or slurries into the vessel without removing the head. This can be done in various ways.

Ball Valve Solids Charging Ports

A ball valve with a 3/8" diameter opening can be installed on any one liter or larger vessel and used in conjunction with a high pressure pipette for injecting slurries under pressure. These are opened or closed with a quarter turn of the handle.

Larger diameter valves are available for 1 gallon and larger vessels. These ball valves will withstand the full pressure developed in a reactor at moderate temperatures, but their pressure rating falls off rapidly at temperatures above 100 °C.



A143VB Ball Valve

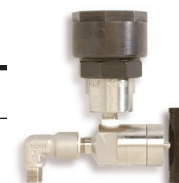

Solids Charging Auger

Solids Charging Ports

Part No.	Nominal Size	Orifice Diameter, in.
A143VB	1/4" NPT (F)	0.250
A132VB	3/8" NPT (F)	0.375
396VBAD	1/2" NPT (F)	0.406

Capped Openings

A capped opening in the head of a reactor can serve as a convenient solids charging port, offering the largest possible diameter and a significantly shorter passage than a ball valve. A male connector with a cap is usually used to close the opening. These will have a reliable metal to metal seal and the ability to withstand the full temperature and pressure for which the vessel is rated.

Tubing can be connected to the fitting, but this type of connector is normally used only where solids or slurries will be added at atmospheric pressure.

Capped Openings

Reactor	Available Fitting Sizes
Mini	1/4" NPT (F)
1 & 2 Liter	3/8" NPT (F)
Gallon & up	1/2" NPT (F)



A550HC Catalyst Addition Device



A550HC Open

Catalyst Addition Devices

Parr has developed a unique device for adding small amounts of solids (or liquids) from a sealed container held within a reactor. It is of particular interest to users performing kinetic studies of catalytic reactions. This device consists of a small cylindrical chamber with a cap that is sealed to the body with an O-ring. It attaches to the underside of the vessel head with a 1/8" NPT connection. To discharge the contents of the holder, gas pressure is applied through a valve installed on the top of the head. When the applied pressure is greater than the

pressure within the reactor, the cap is forced open and the catalyst or other contents of the holder will be released into the reactor. This device works best in the taller, 450 mL and 600 mL Mini Reactors, and in the 1 liter and larger Parr Reactors.

Liquid

Complete Reactor	Mounting Size, cc	Assembly No.	Thread
Mini	6	A550HC3	1/8" NPT
One Liter	8	A550HC	1/8" NPT
Larger	20	A550HC2	1/8" NPT

Cooling Coils

Liners



Serpentine Cooling Coil 1000 mL



Spiral Cooling Coil 1000 mL

Internal cooling coils are available for all but the smallest Parr reactors. These coils provide an extremely effective means of removing heat from the vessel to control an exothermic reaction or for cooling the reactor at the end of a test. Since heat is transferred through the relatively thin wall of the coil instead of the thick wall of the vessel, cooling rates are generally much faster than heating rates; particularly at temperatures above 80 °C. Water is normally used as the cooling medium although compressed air can be used for modest cooling loads. Cooling coils are offered in three standard configurations:

Single Loop - Single loop coils consist of a vertical run of tubing formed into a "hairpin" shape. These are normally installed on small reactors where there is minimum space available.

Serpentine Coils - Serpentine coils consist of six to eight vertical runs of tubing uniformly spaced around the circumference of the vessel.

These coils provide reasonable surface area, minimum interference with stirring patterns, a reasonable amount of baffling, and ease of cleaning and maintenance.

Spiral Coils - Spiral coils consist of multiple loops wound just inside the inside diameter of the vessel. They are normally available only for the 4" and 6" ID vessels although other sizes have been built on special order. They do maximize the cooling area available, but sometimes at the expense of uniform stirring and ease of cleaning.

The individual reactor specifications will dictate the style of coil or coils available for each reactor. On some reactors the coils are included as standard while on some reactors they are optional.

Cooling coils are available in the same choice of materials as the reactor bodies themselves. All cooling coils are removable. Plugs are available to close the openings in the head and in most cases these openings can be converted to alternate inlets/outlets if cooling is not required.

Removable, open top, cylindrical liners made either of borosilicate glass or PTFE can be furnished to fit most Parr reactor and most of the general purpose vessels. These liners slide into the cylinder and require no additional fittings, but they may not coordinate with some alternate accessories and stirrers. Although they will not keep corrosive vapors from reaching the surfaces of the cylinder and head, they make it much easier to add and remove liquid reactants, and they give some protection to the cylinder when working with corrosive solutions. It must be noted, however, that adding a PTFE liner will slow the heat transfer rate into and out of the vessel, and it may be necessary to adjust the temperature control method to prevent overheating.

Liners

Fits ID, in.	Cylinder Size, mL	Glass Liner Part No.	PTFE Liner Part No.
1.3	50	1431HC	1431HCHA
1.3	100	1431HC2	1431HC2HA
1.5	75	2920HC	2920HC2HA
2-1/2	250	762HC10	NA
2-1/2	500	762HC2	NA
2-1/2	300	762HC	762HC4HA
2-1/2	450	762HC2	762HC5HA
2-1/2	600	762HC3	762HC6HA
2	100	762HC7	762HC7HA
2-1/2	160	762HC8	762HC8HA
3-1/4	600	2312HC	2312HC3
3-1/4	1200	2312HC2	2312HC4
3-3/4	1000	1441HC	1441HCHA
3-3/4	1800	1442HC	1442HCHA
4	1000	398HC	398HCHA
4	2000	399HC	399HAHA
6	1 Gallon	894HC	894HC4HA
6	2 Gallon	894HC2	894HC5HA



Glass Liners 2000 and 1000 mL Sizes
Temperature Limit: 565 °C



PTFE Liners 2000 and 1000 mL Sizes
Temperature Limit: 225-250 °C

Sample Collection Vessels



A sample collection vessel can be added to most reactor systems. Designed to efficiently and safely allow for the withdrawal of liquid or vapor samples at elevated temperatures and pressures, this quick close, O-ring seal vessel has a volume of 10 mL and is designed for operating pressures to 3000 psi (200 bar).

The typical arrangement for this sample vessel includes a cooling sleeve, isolation and vent valves. A drain valve may also be added to the vessel.

The isolation valve is mounted at the head of this vessel and is used to seal the vessel once the sample is transferred. The vent valve is installed in a tee and is used to release any residual pressure in the line between the sample valve and the sample vessel. Samples can be removed either by opening the collection vessel and pouring it out or by use of the drain valve.

Standard material of construction is T316 Stainless Steel but it can be provided in any of the other alloys if required. A high pressure sample collection vessel without a cooling sleeve for pressures to 5000 psi is available upon request.

Sample Collection Vessels

Part No.	Description
4351	Sample Collection vessel, 10 mL, with cooling sleeve, isolation & vent valves for connection to 1/8" NPT valves
4352	Sample Collection vessel, 10 mL, with cooling sleeve, isolation & vent valves for connection to 1/4" NPT valves
4353	Sample Collection vessel, 10 mL, with cooling sleeve, isolation & vent valves for connection to 3/8" NPT valves
-D	Optional Drain Valve

Bottom Drain Valves



A465VB Bottom Drain Valve

Bottom drain valves can be added to most Parr reactors. These valves are particularly useful for those working with polymers or other material that must be discharged from the reactor while they are still hot and before they can solidify. These valves are also quite useful for the 1 gallon and larger vessels which are too large to conveniently lift from the heater for product recovery. Bottom valves are rarely installed on the micro and mini reactors with their small volumes and light vessel weights.

The standard bottom drain valve has a rising stem, that is flush with the inside cylinder bottom so that there is no dead space between the bottom of the vessel and the shut off point of the valve. In the fully open position the stem is retracted completely to open a clear passage for draining the vessel.

When the valve is reclosed, any material in this passage will be pushed back into the reactor by the rising stem.

Valves with 3/8" diameter clear passage are recommended for vessels with volumes from 1000 mL to 2 gallons. A 1/4" valve is available for 600 mL and

smaller vessels. High pressure and larger diameter valves are available where required.

These valves will withstand the full operating pressures and temperatures of the vessels in which they are installed. They are available in nearly all of the current Parr materials of construction. Air actuated valves are available for larger reactors. Users can also specify that a reactor ordered with a bottom valve shall have a tapered bottom so that it will drain easily through the valve opening.

Not all Parr reactors will accept a bottom drain valve. Since the valve extends approximately 8 inches below the bottom of the vessel, the entire vessel must be raised by this amount to accommodate the valve. This makes some models too tall for convenient bench top operation. The specification tables for each model will identify those reactors in which a bottom drain can be readily installed, and those which will not accept a bottom drain, or those which will require custom modification of the heater and support stand to accommodate a bottom valve.

Needle Valves and Ball Valves

Needle valves and ball valves can also be installed as bottom outlet valves. Needle valves are generally used on the smaller reactors. While ball valves can be used for large discharge passages, they are generally limited in their operating temperature/pressure capabilities and they leave a fairly large dead space between the bottom of the vessel and the seat of the valve.

Bottom Drain Valves

Part No.	Opening Dia., in.	Outlet Connection	Max. Press., psi	Max. Temp., °C	Seal
A485VB	0.25	1/4" NPT (F)	3000	225	PTFE
A485VB2	0.25	1/4" NPT (F)	3000	350	Silver
A465VB	0.38	3/8" NPT (F)	2000	350	Grafoil
A465VB2*	0.38	3/8" NPT (F)	2000	350	Grafoil
A465VB3	0.38	3/8" NPT (F)	2000	350	Silver
A177VB	0.31	3/8" NPT (F)	5000	500	Grafoil
A296VB	0.69	1" NPT (F)	1900	265	PTFE

* Set up for a Band Heater.



Valves and Fittings

Parr stocks and can install a wide variety of valves and fittings for use with reactors and pressure vessels. These include:

- Needle Valves with NPT or tube connection.

- Regulating Valves with NPT or tube connection.
- Ball Valves with NPT or tube connection.
- High Pressure Valves
- Severe Service Valves
- Remote Operating Valves
- Tube Connectors
- Pipe Connectors
- Plugs
- Union Coupling Adapters

Please contact our customer service department for details.

Manual Control Valves for Compressed Gas Tanks

Tank valves with couplings to fit standard compressed gas cylinders are available in stainless steel for corrosive gases and in nickel plated brass for non-corrosive gases. The brass valves have a 2-1/2" diameter pressure gage which shows the tank pressure. Both styles have a 1/4" NPT female outlet which will accept any pressure hose or gas tube assembly. These valves do not regulate the delivery pressure of the gas. Pressure regulators are available on special order.

T303 Stainless Steel Valves-No Gage

Fits CGA Tank Valve No.	Outlet No.	Typical Usage
A120VBPN	510	Propane, butane, ethylene oxide
A120VBPP	660	Chlorine, sulfur dioxide, nitric oxide

Nickel-Plated Brass Valves with Cylinder Pressure Gage

Fits CGA Tank Valve No.	Outlet No.	Typical Usage
A120VBPQ	320	Carbon dioxide, methyl bromide
A120VBPR	350	Hydrogen, carbon monoxide, ethylene
A120VBPS	540	Oxygen
A120VBPT	580	Nitrogen, argon, helium
A120VBPU	590	Air

Note: Can be furnished with DIN/BSP connections on special order

Safety Check Valves

Whenver gases or liquids are introduced into a vessel under pressure, the supply pressure must be greater than the pressure in the vessel to prevent reverse flow back into the supply system. Protection against reverse flow can be obtained by installing a check valve in the supply line. With a check valve in the line, the valve will snap shut if the supply pressure is too low, or if the pressure in the vessel should rise above the supply pressure. This protection is particularly important on stirred reactors where gas enters through a dip tube. With liquids in the vessel, any

back pressure will force liquid back into the gas tank or into the gas supply system.

Parr stocks the poppet check valves listed above for incorporation into the user's supply lines. These valves have a 10 psi normal cracking pressure and are rated for 3000 psi maximum working pressures. Check valves with other specifications can be furnished on special order.

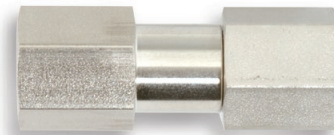

363VB Check Valve



364VB Check Valve

Poppet Check Valves

Part No.	Material	Connections
363VBAD	Stainless	1/4" NPT (F)
364VBAD	Stainless	1/4" Tube

Thermocouples

Parr offers a variety of thermocouples for use in our reactors and pressure vessels. The “standard” thermocouple is a Type J (iron-constantan) which is well suited to the operating temperature range of these vessels. Other materials as well as platinum resistance (RTD) elements are available as special orders. These thermocouples are sealed in 1/8" diameter stainless steel sheaths and have a standard plug connection at the end of the probe.

These thermocouple assemblies can either be sealed directly into the head of the vessel using a male connector with an 1/8" NPT thread or

inserted into a protective well. Thermowells are used on larger vessels to protect the thermocouple from physical damage and on all vessels of a corrosion resistant alloy other than stainless steel.

Dual element thermocouples with two separate thermocouples in a single sheath and spring loaded thermocouples designed to be installed through the heater to the outside wall of the vessel are also available.

Thermocouples should be approximately four inches longer than the depth of the vessel so that a smooth bend can be made at the top to clear other head fittings.

The A470E2 extension wire is used to connect the thermocouple to the control or readout device. The standard length is six feet, but longer lengths are available.

Type J Thermocouples with 1/8" Diameter

Part Number	Stem Length, in.	Sheath Material
A472E	7.5	T316 Stainless Steel
A472E2	9.5	T316 Stainless Steel
A472E3	11.5	T316 Stainless Steel
A472E6	15.5	T316 Stainless Steel
A475E5	21.5	T316 Stainless Steel
A472E4	5.5	T316 Stainless Steel
A472E8	2.5	T316 Stainless Steel

Most of the above listed thermocouples are also available as Type K (Chromel-Alumel).

Pressure Hose

Three different pressure hose assemblies are available for high pressure gas connections to both stirred and non-stirred vessels. The standard hose is a 6 foot length with a male “A” socket connector on one side and a 1/8" NPT (M) nipple with a 1/4" NPT (M) bushing on the other end. The “A” socket side of the hose attaches to couplings installed on the inlet valve of all stirred reactors as well as to a side port of the gage block assembly for the non-stirred vessels. The choice of either 1/8" NPT or 1/4" NPT on the opposite end of the hose allows for attachment to most gas tank valves, pressure regulators or other gas supply sources.

The A495HC Hose Assembly is made of nylon. It is rated for 2500 psi and is very flexible and easy to use with dry, non-corrosive gases (nitrogen, hydrogen and oxygen). Care must be taken to ensure that the nylon hose does not come in direct contact with any

hot surfaces on the vessel or heater. One of these hoses is included with each complete Parr Series 4500, 5100, and 5500 Stirred Pressure Reaction Apparatus.

The A490HC Hose Assembly is a braided, stainless steel hose with a PTFE lining, rated for 2500 psi. It is reasonably flexible and recommended for use with corrosive gases and liquids, and for applications requiring additional abrasion resistance, but it is not intended for high temperature liquids or gases.

The A506HC Assembly is a 6-foot length of 1/8" OD stainless steel tubing, rated for 7500 psi. This small diameter tubing



**A506HC
Hose Assembly**



**A490HC
Pressure Hose**

is “bendable”, but it is not as flexible as the other hoses. It is recommended for corrosive gases, high temperature transfers and other high pressure applications. Special versions of this assembly can be made of other corrosion resistant materials. Larger tubing can be used, but it is rigid rather than flexible.

Special hoses with different lengths or end fittings can be assembled for special orders.



**A495HC
Pressure Hose**

Pressure Hose

A495HC	Pressure hose assembly, 6-ft, reinforced Nylon
A495HC5	Pressure hose assembly, 6-ft, reinforced Nylon, with non-return valve
A495HC7	Pressure hose assembly, 10-ft, reinforced Nylon
A490HC	Pressure hose assembly, 6-ft, PTFE-lined, braided stainless steel
A490HC5	Pressure hose assembly, 6-ft, PTFE-lined, braided stainless steel, with non-return valve
A506HC	Gas tube assembly, 6-ft, 1/8" OD, T316SS

Alternate lengths available upon request.

Explosion Proof Apparatus



All Parr reactors are normally equipped with open type, variable speed motors, electric heaters and controllers intended for use in non-hazardous environments. These standard units can be used in most laboratories without undue hazard, but there will be situations where the installed equipment must be considered explosion proof. Parr offers various optional stirrer drives and heating systems to meet these strict requirements.

USA and International Codes

Designing electrical equipment to be operated in a hazardous location is a complex subject, governed by extensive national electrical codes and supplemented by local regulations which require that all electrical equipment installed in a governed location must be approved for use with the specific gas, vapor or dust that will be present in that location. USA electrical codes classify hazardous locations according to the nature and concentration of specific hazardous or flammable materials. These are divided into three classes:

Class I - Flammable liquids, gases or vapors.

Class II - Combustible or electrically conductive dusts.

Class III - Easily ignitable fibers or flying particles.

There are two divisions within each of these classes.

Division 1 - Where the flammable material exists in the atmosphere under normal operating conditions.

Division 2 - Where the hazardous material is confined within a closed system from which it may be released only under abnormal conditions, such as a leak in the system.

Class I locations are further subdivided into four Groups, A, B, C and D which identify specific explosive gases and vapors. Explosive dusts and fibers in Class II are subdivided into Groups E, F and G. Most hazardous applications for Parr apparatus will occur in atmospheres identified by Class I, Group A for acetylene, Group B for hydrogen and Groups C and D for most other combustible gases and vapors. Class II, Group F covers coal dust. Most other combustible dusts, such as flour and grain, are in Group G. Minimum ignition temperatures and energy levels are established for specific materials in each group.

The European Community uses a significantly different convention identified as ATEX or Atmospheres Explosives. In this, the user must identify the level of protection required for their installation. Parr will work with our customers operating under ATEX to provide equipment meeting current ATEX requirements.

Explosion Proof Motors

Because of sparking from brush contacts, electric motors clearly represent the principal explosion hazard introduced by a stirred reactor. Electric motors approved for Class I-Division 2, Groups C and D, and Class II, Groups F and G atmospheres are readily available in most sizes and voltages. These sealed motors are suitable for most hazardous applications, and they are sometimes used with hydrogen, but they are not approved for Class B atmospheres. To meet Class B requirements, a motor must be purged by building up a positive pressure of air within the motor to prevent explosive gases or vapors from reaching electrical



Model 4524 Reactor, 2000 mL, Fixed Head Style with Aluminum Block Heater

ignition sources. This requires a special, air purged motor which can be provided when required.

An alternate method of dealing with the explosion hazard is to use an air driven motor. These are powered by compressed air and offer a convenient and satisfactory drive system for use in flammable atmospheres, including hydrogen. They are available in sizes suitable for all Parr reactors.

Explosion Proof Apparatus, Continued



Air Motor

Explosion Proof Heaters

The easiest way to provide an explosion proof heater is to use a steam or hot oil jacket and ensure that the highest temperature that can be reached in the jacketed cylinder is well below the minimum ignition temperature for the specific hazardous atmosphere in which it will be installed. An aluminum block heater can be considered explosion proof if it has explosion proof wiring, and if it is operated with an auxiliary controller that will hold the surface temperature below a safe maximum.

Electric heaters purged with clean air can also be considered explosion proof, but it is doubtful that seals can be maintained in a purged heater to provide true protection over a long period of time.

Please see page 102 for additional information on heater selection.

Explosion Proof Wiring

In an explosion proof system, all electric wiring with significant voltage or current carrying capability must be routed in approved sealed conduit or in specially sealed flexible cables. All terminations and switches must be contained in approved boxes

or housings. The user must provide all local wiring and connections to a power supply, and must ensure that the installation meets all requirements of the local electrical code.

Certain sensors, such as thermocouples, pressure transducers and tachometer pickups carry such low electric loads that they are a potential ignition source only in the event of a most unusual failure. In many installations these low hazard components are not seen as a problem. They can, however, be protected with isolation barriers which will make them intrinsically safe even in an unusual failure. These energy limiting electronic barriers can be provided where required.

Explosion Proof Controllers

The most commonly used method for dealing with the ignition hazard introduced by a temperature or process controller is simply to locate the controller outside of the hazardous atmosphere. Another choice is to install the controller in a cabinet which can be purged with clean air within the hazardous location.

Special Systems

Parr can furnish systems approved for use in hazardous locations up through Class I, Division 1, Group B in which specific hazardous gases will be present. Each of these formally approved systems must be designed and built on a custom basis, with all current carrying wiring and fittings installed in accordance with the requirements discussed above.

Windows



Windows can be installed in Parr stirred reactors and pressure vessels for visual observations, light transmission and other purposes. They usually are installed in pairs so that light can be introduced through one window while the other is used for viewing. Our standard material for these windows is quartz. Sapphire is also available for small diameter windows. Alternative window materials are available for specific transmission requirements. They can be mounted in several different ways.

Screw-in Circular Windows

The simplest window is a screw-in type with a 1/2" diameter viewing area. The element in these windows is sealed in a fitting which screws into the vessel using a standard 1/2" NPT male pipe thread. Obviously, the vessel wall must be thick enough to provide full engagement for this thread. PTFE gaskets and O-ring seals restrict the maximum operating temperature to 225 or 275 °C, depending upon the O-ring material. Pressure ratings range from 2000 to 5000 psi, depending upon the window material and its thickness. Although these windows are rather small for straight optical viewing, they work well for small video systems and for laser and other analytical beams. A limitation of this design is that there is a dead space approximately 1-1/4" long between the inner face of the window and the inside wall of the vessel.



100 mL Vessel Based On 2430HC3 Cylinder, with Two Quartz Windows

Integral Windows

Parr has developed designs for installing windows in the wall of the vessel so that the inside face of the window is very close to the inside wall of the vessel. This eliminates the large dead space associated with screw-in windows. These windows are offered in the two styles described below. The maximum size of the window will depend on the size of the cylinder in which it will be installed.

Circular Windows with a 0.5" or 1.0" diameter viewing area are the standard. Circular windows are available in a variety of materials including sapphire for very high pressures. This type of window is generally used for visual, photographic or optical sensor observations.

Oblong Windows with a viewing area 3.50" long and .62" wide are the standard size and can be installed on vessels of 100 mL and larger. These windows are commonly used for visual observations in both the vapor and liquid phases



Pressure vessel with multiple 1-inch diameter windows installed.

and for observing the liquid level in the vessel. Multiple windows can be stacked on larger vessels.

Windows in both the round and oblong styles can be furnished in larger sizes upon request. The windows we have noted above as standard are maintained in our inventory for readily available replacements.

All reactors and pressure vessels equipped with windows require custom designed heaters and supports. Flexible heating mantles and attached circulating jackets are the most commonly used heaters for window vessels.

Windows are sealed into these vessels with O-rings. For this reason, vessels equipped with windows are restricted to operating temperatures of 225 or 275 °C depending upon the O-ring material selected.

A variety of insulated electrical leads can be installed in any Parr reactor or pressure vessel for electrical measurements or to supply power to an internal heater or other devices. Three different gland designs are available. These screw into a vessel and will have pressure and temperature ratings to match those of the vessel in which they will be used.

Transducer Glands

Transducer glands are used for applications requiring a number of small insulated wires in a single gland. Wire sizes from 14 to 24 gage are used to carry small currents and voltages in the millivolt range. A unique feature of this design is that multiple wires (up to 16) can be individually insulated through a single gland.

Electrode Glands

Applications requiring a single electrical conductor with current carrying capacities from 20 to 100 amperes and voltage ratings to 2000 volts can be handled with an electrode gland. These glands have a single conductor (or electrode) in sizes from 0.093 to 0.312-inches in diameter, with the ends of the conductor threaded so that internal and

external lead wires can easily be attached.

Power Leads

Power leads can be provided with either single or multiple flexible wires in sizes from 14 to 18 gage. Current ratings range from 5 to 20 amperes at up to 600 volts. Either PTFE or ceramic insulation is available. Ceramic glands can be used to the full temperature rating of any Parr vessel. Pressure ratings will vary from 1000 to 10000 psi, depending upon the design of the gland, its size and the type of insulation used.

Miscellaneous Sensors

Parr has installed a number of different sensors in its various reactors and pressure vessels, including both single point and continuous liquid level sensors, pH electrodes and dissolved oxygen electrodes. Each of these installations must be carefully developed in consultation with the user, the electrode or probe supplier and the Parr Engineering Department. Glass electrodes with O-ring seals will carry rather severe temperature and pressure restrictions. There are also space restrictions which generally dictate that accessories of this type can only be installed in 1000 mL or larger vessels.

There are a number of factors that determine the maximum temperature rating of a pressure vessel. For most applications it is the gasket material. Vessels with O-ring seals are limited to 225 °C unless exotic materials are used to extend this temperature to 275 °C. Parr's design for contained PTFE gaskets extends the operating temperature range to 350 °C. Flexible Graphite (FG) material essentially removes the gasket as the limiting factor. Maximum temperature limits for the metals used in these vessels are established by ASME code and other standards. Most metals have maximum temperature limits between 400 and 800 °C. The allowable strength for these metals falls off rapidly as they reach maximum operating temperature. Finally, the difficulties encountered with screw threads and other closure components operating at high temperatures establish a practical temperature limit for externally heated vessels. We have found 600 °C to be a reasonable limit.

Internally Heated Vessels

Exposed Heaters. Another approach has proven useful in extending the maximum temperature limit. In this design the heater or furnace is placed inside the pressure vessel. The heater is surrounded by a layer of insulation. This creates a hot zone in the center of the vessel and prevents the walls from exceeding their allowable limit. Properly designed, temperatures as high as 1200 °C can be achieved in the core of the vessel while the walls remain below 250 °C. This system is very energy efficient. Internal heaters can be less

Spare Parts Kits

Each stirred reactor is furnished with a set of spare parts and fittings including a 6-foot gas supply hose, head gaskets, rupture discs, and a set of replacement parts for the stirrer drive.

A reserve supply kit of spare parts can be ordered from Parr Technical Service to provide sufficient parts and tools to handle most normal replacements and emergency repairs during the first year

of heavy usage. These kits include replacement gaskets, O-rings, rupture discs, drive belts, and seals. These kits are a convenient package of the small perishable items required for normal maintenance of the reactor.

When ordering any kit for an existing reactor please specify the preferred gasket/seal material, the range of the rupture disc, material of the reactor, and the length of the drive belt.

External Valves and Fittings



powerful than external heaters. Internally heated vessels are equipped with insulated electrical feed-throughs to power the heater and multiple thermocouples to monitor and control the temperatures in the hot zone and the vessel inner wall.

The reactions or studies carried out in internally heated vessels must be limited to those which will not destroy the exposed internal heaters and insulation. These are normally gas-solid reactions or controlled atmosphere heat treatment studies. The heating elements are normally ceramic. Some users have developed induction style heaters and insulators and have extended their investigations to above 2500 °C.

Although internal heaters can be installed in almost any non-stirred Parr pressure vessel the 1.8 liter, Model 4683 High Pressure/High Temperature vessel is an excellent starting point. It can accommodate a cylindrical, insulated heater 1.75" diameter by 8" deep, capable of producing and sustaining internal temperatures to 1200 °C.

Protected Heaters.

Internally heated vessels have also been manufactured with cartridge type heating elements inserted in specially designed "thermowells". These wells protect the heater from the reactants and expand the applications that can be studied. Cartridge type heaters have a maximum temperature of 760 °C.

Materials of Construction

In the standard configuration, the valves, gage, magnetic drive and other external parts on Parr reactors are furnished in stainless steel, even when a different material is specified for the cylinder, head and internal wetted parts. The external stainless components are typically only exposed to the vapor of the reactants and are at much lower temperature than the cylinder and internal fittings. These conditions allow stainless steel external fittings to perform satisfactorily in most cases. If external parts made of a material other than stainless steel are required for safety or other reasons, Parr can accommodate this in most cases. Any request for external parts made of a specific material must be stated clearly when ordering.

Valves

Most reactor valves are available in Alloy 400 as well as stainless steel at a reasonable cost premium. Valves made of Alloy C-276 are also available, but generally only on special designs and at a considerable cost premium. Soft materials such as titanium and zirconium generally make poor performing valves.

Gages

Pressure gages are available in Alloy 400 and stainless steel. Other materials of construction are not available. The standard method for protecting the gage in a corrosive environment is to install a diaphragm gage protector. These have a flexible diaphragm which isolates the gage from the reactants and a sealed hydraulic connection for pressure transfer to the gage. These assemblies are too large to install on all but the largest Parr reactors.

As an alternative, Parr has designed an oil filled piston isolator gage protector to isolate the gage (and transducer, if required) on small reactors and pressure vessels where space is limited. These isolators can be furnished in any of the current Parr materials of construction.

Pressure Transducers

Pressure transducers are only available in stainless steel and Alloy C-276. Parr provides a mounting adapter with a water cooling jacket on pressure transducers to protect them from excessive temperatures. These can be augmented with piston style isolators similar to gage protectors when corrosion resistance is required. When a gage and a pressure transducer are installed, a single isolator can protect both.

Magnetic Drives

Magnetic drives can be furnished in all of the current Parr materials of construction except nickel, which is magnetic.

Rupture Discs

The standard material of construction for rupture discs is Alloy 600. A gold facing is available for the smaller discs used on vessels up through 2 liters in volume. Alloy C-276, Tantalum and other premium materials are available on special order.

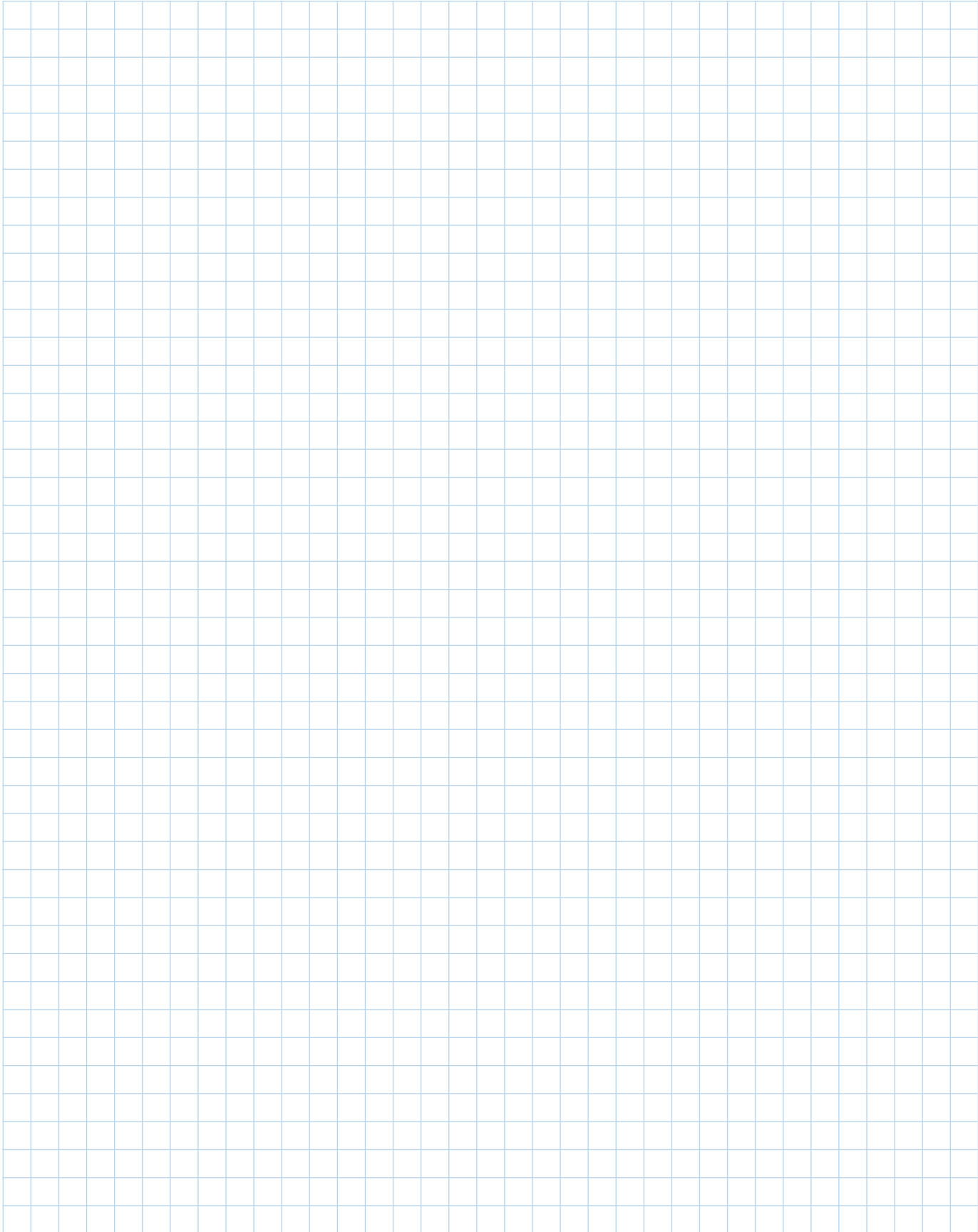



Parr Instrument Company

211 53rd Street
Moline, Illinois 61265 USA
Phone: 1-309-762-7716 or 1-800-872-7720
Fax: 1-309-762-9453
E-mail: parr@parrinst.com
Web: www.parrinst.com